

# eco Ai circular

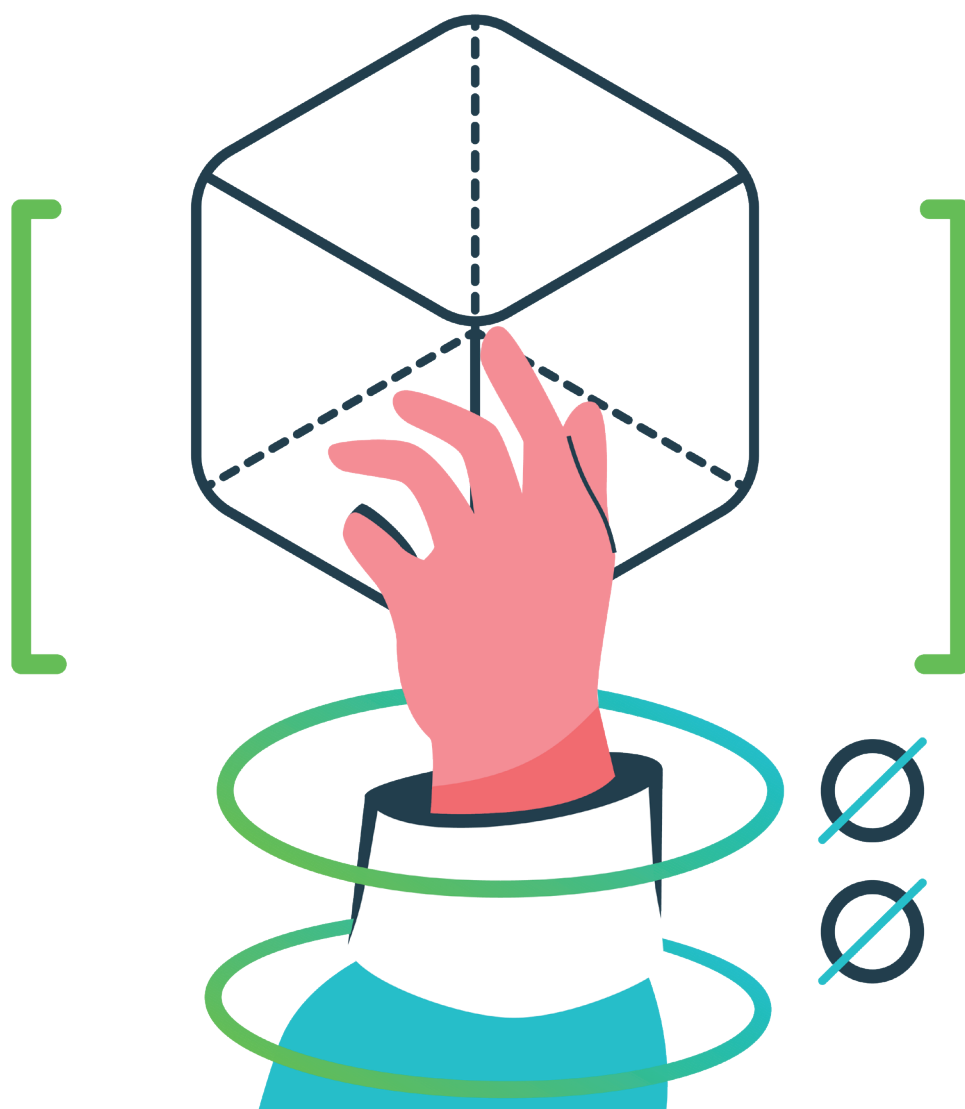

## Assignments



Co-funded by  
the European Union

Co-funded by the European Union (2023-2-ES01-KA210-VET-000180154). Views and opinions expressed are however those of the author(s) only and do not necessarily reflect those of the European Union or the Spanish Service for the Internationalisation of Education (SEPIE). Neither the European Union nor SEPIE can be held responsible for them.

## Assignments

### Assignment 1: The importance of sustainability in electronics manufacturing

#### Exercise

After watching the videos, discuss in groups or individually the following questions:

#### Discuss

- The environmental issues associated with e-waste.
- Identify and select sustainable materials useful for cell phones.

---

### Assignment 2: Evaluation of circular business models in the electronics industry

#### Exercise

After reading the documents listed in Material List for this Assignment, discuss in groups or individually some of the following questions:

#### Discuss

- How can businesses in the electronics industry transition from a linear to a circular model without sacrificing profitability?
- What are the main barriers companies face when adopting circular business models, and how can they overcome them?
- What role do consumers play in promoting or hindering circularity in electronics?
- How do product-as-a-service models (PaaS) change the relationship between businesses and consumers in the electronics industry?
- What are the environmental and social impacts of e-waste, and how can circular strategies help mitigate these issues?
- In what ways can digitalization support the implementation of circular business models in the electronics sector?
- Why electronic waste is such a big problem? What are some of the things that can be done to reduce electronic waste?
- Do you think the transition to a circular economy is inevitable? Why or why not? What are some of the challenges that we need to overcome in order to make this transition?



## CASE STUDY: EcoMobileX1's Green Efficiency

### Assignment 3: Understanding the company and the process of EcoMobile X1

#### Introduction of EuroTech Industries

EuroTech Industries is a manufacturing company specializing in the production of electronic devices for cell phones. The company is facing economic challenges due to rising material costs and increased competition in the market. Additionally, EuroTech Industries has been criticized for its environmental impact, particularly for generating a large amount of electronic waste (e-waste) and consuming excessive amounts of electrical energy.

EuroTech Industries produces high-tech cell phones equipped with a variety of advanced components. These include a high-resolution OLED display, state-of-the-art processors, printed circuit boards (PCBs), high-speed RAM, and high-capacity internal storage. At the electronic level, the devices incorporate key elements such as motherboards, chipsets, Wi-Fi and Bluetooth connectivity modules, power management circuitry, proximity and ambient light sensors, high-definition cameras with multiple lenses, stereo speakers, and long-life lithium-ion batteries. Each component is designed to maximize performance and energy efficiency, using advanced materials that ensure durability and optimal performance.

#### Description of EcoMobile X1

- **Screen:** 6.5-inch OLED, resolution 1440 x 3040 pixels
- **Processor:** EcoChip X1, 8 cores, 2.84 GHz
- **Memory:** 8 GB RAM, 128 GB internal storage (expandable up to 1 TB)
- **Rear Camera:** Dual 48 MP + 12 MP, 4K video recording
- **Front Camera:** 32 MP
- **Battery:** 5000 mAh, fast charging and wireless charging
- **Operating System:** Android 12
- **Connectivity:** 5G, Wi-Fi 6, Bluetooth 5.2, NFC
- **Retail Price (including taxes):** 800 euros
- **VAT:** 21%

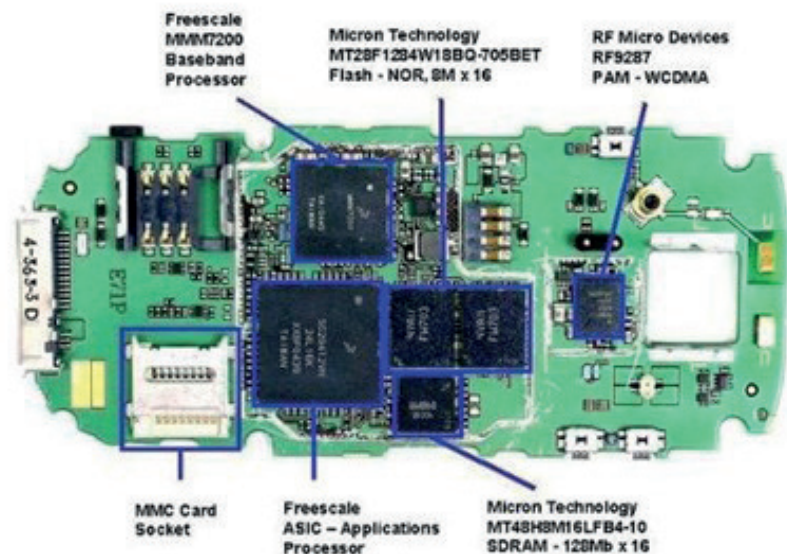

## Challenge 2

Recently, as an employee of EuroTech Industries, you have been tasked with improving the sustainability of the company's manufacturing processes. Specifically, you are responsible for developing an action plan that focuses on enhancing the sustainability of the production process, particularly in relation to the reuse and repair of high-value technological components, such as the PCBs used in EuroTech's cell phones.

After becoming aware of the environmental and toxic impact of a mobile phone, first of all you have decided to analyze the various stages of manufacturing the EcoMobileX1 mobile phone to determine how to achieve a more sustainable life cycle.

The main production stages that EcoMobile X1 goes through at IndustriesSL are as follows:

- **Stage 1. Design and Development:** Conceptualization and Prototyping
- **Stage 2. Component Manufacturing:** PCB Fabrication, Screen Production and Battery Production
- **Stage 3. Assembly:** Component Assembly and Software Installation
- **Stage 4. Testing and Quality Control:** Functional Testing and Durability Testing
- **Stage 5. Packaging and Distribution:** Packaging and Distribution

### Discuss

- Considering the environmental and toxic impacts associated with mobile phones, evaluate the production stages of the EcoMobileX1. Identify areas for improvement in its life cycle to enhance its sustainability,

After discussions with EuroTech's engineers, it becomes clear that the focus of your sustainability plan should be on the PCB Fabrication stage. PCBs serve as the backbone of the phone's electronic components, including microchips, resistors, and capacitors.

Your goal now is to improve the sustainability of the EcoMobileX1's PCBs. To achieve this, you need to conduct a comprehensive analysis of:

- The PCB's life cycle,
- The selection of the sustainable materials
- The PCB reuse strategies
- The PCB repair strategies
- And the sustainable design principles



Co-funded by  
the European Union

Co-funded by the European Union (2023-2-ES01-KA210-VET-000180154). Views and opinions expressed are however those of the author(s) only and do not necessarily reflect those of the European Union or the Spanish Service for the Internationalisation of Education (SEPIE). Neither the European Union nor SEPIE can be held responsible for them.

By addressing these aspects, you will create a comprehensive plan to enhance the sustainability of the entire production process.

The following questions are designed to guide you in developing a comprehensive action plan. By addressing each question, you will be able to systematically analyze key aspects, identify potential challenges, and develop effective strategies:

## Discuss

- Analyze the main stages of the PCB life cycle, from raw material extraction to final disposal.
- Identify the environmental impacts associated with each stage, focusing on energy consumption, material waste, and toxic emissions.
- Identify criteria for selecting sustainable materials for PCB manufacturing, including reduced toxicity, lower energy requirements, and recyclability.
- Propose alternative materials that could replace conventional ones, such as bio-based polymers or recycled metals.
- Explore strategies for reusing discarded PCBs, such as component salvaging or modular design.
- Identify PCB components that are easily reusable, such as capacitors and microchips, and propose strategies to maximize reuse efficiency.
- Study repair techniques for PCBs in mobile phones and explore ways to design for easier repairs.
- Research methods to incentivize customers to choose repair over replacement, such as offering extended warranties, repair services, or discounts for repairing phones instead of replacing them.
- Investigate the principles of ecological design and how they can be applied in electronics manufacturing.
- Research ways to design PCBs so that they are easier to repair, reuse, and recycle.



## Assignment 4: Implementing Sustainable Strategies

### Exercise

As an employee, you are required now to design and present a comprehensive action plan aimed at enhancing the sustainability of the EcoMobileX1. Your plan should be detailed and structured according to the project template provided, ensuring that it includes all relevant research, strategies, and insights gathered during the previous stages of the assignment.

Your action plan must cover key areas such as material selection, production processes, and waste management solutions. Consider implementing the **10 R's of Circular Economy** (Refuse, Rethink, Reduce, Reuse, Repair, Refurbish, Remanufacture, Repurpose, Recycle, and Recover) into the plan to create a fully circular production process.

Once your plan is developed, you will present your findings and proposed strategies clearly, demonstrating how these measures will reduce the ecological footprint of the EcoMobileX1 while maintaining or improving its market competitiveness.

